

P10 Series

Overhead Stop

Heavy duty | Concealed mount



Description

The P10 Series concealed mount overhead stop is designed and tested in accordance with ANSI/BHMA A156.8, meeting Grade 1 requirements and exceeding 250,000 cycles for heavy-duty performance and long-term reliability. The concealed design ensures a clean, unobtrusive appearance while maintaining robust functionality.

Engineered to deliver effective door control with a positive stop function, the P10 Series prevents over-opening and provides reliable stopping action, protecting doors, frames, hinges, and door closers from damage caused by heavy traffic or abuse. Optional hold-open functionality is available to suit different application requirements.



Compatible with a wide range of door and frame configurations with different hinges, it is suitable for both wood and metal doors. The unit is field adjustable to accommodate door opening angles from 90° to 110°, and is available in multiple channel sizes to suit various door widths.

Ideal for high-traffic commercial environments such as offices, healthcare facilities, and educational buildings, the P10 Series ensures dependable performance even under demanding conditions.

Features & Advantages

- Works in conjunction with floor door stoppers for improved door control and protection on the top
- Positive dead stop at selected opening angle to prevent over-travel and damage
- Spring cushions the door before it reaches full open stop
- Stainless steel channel and arm for strength and corrosion resistance
- All-metal construction as standard, suitable for fire-rated doors
- Suitable for high-traffic and heavy-duty commercial applications
- Protects door, frame, hinges, and door closer from impact damage
- Adjustable for different door opening angles and installation conditions
- Compatible with a wide range of door types and hinge systems

Certification & Compliance

	<p>Certified with ANSI/BHMA A156.8 Grade 1 function and strength. Tested over 250,000 cycles.</p>
	<p>ANSI/UL 10B, Fire Tests of Door Assemblies. ANSI/UL 10C, Positive Pressure Fire Tests of Door Assemblies. CAN/ULC-S104, Standard Method for Fire Tests of Door Assemblies.</p>

Specifications

ANSI no.	C01541
Type	Heavy duty
Installation	Concealed
Function	Stop
Door type	Interior/exterior, single/double acting
Door thickness	Min. 1-3/4" (44mm)
Door width	24"~50" (610~1270mm)
Handing	Non-handed
Door opening	90°~110°
Channel	C-shaped SS304 channel, 1-1/8" (29.4mm) section, thickness 1/8" (2.7mm)
Arm	SS304, thickness 3/16"(5mm)
Jamb bracket	SS304, thickness 1/4" (6.35mm)
Slider	Galvanized CRS, thickness 1/16" (2mm)
Shock block	Galvanized AISI1045
End caps	ZAMAK 5 Zinc alloy
Finishes	US32D

Channel Length Options

Model No.	Channel Length	Function	ANSI No.
P101	16-11/16"	Stop	C01541
P102	17-15/16"		
P103	19-7/16"		
P104	21-9/16"		
P105	23-1/16"		

Product Components

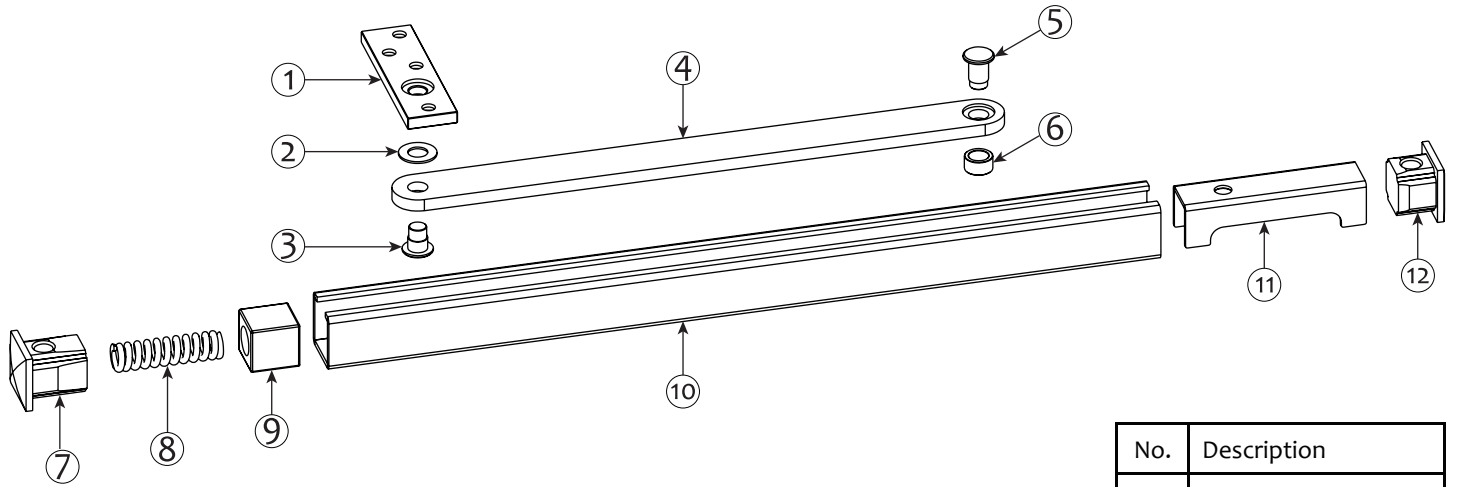

No.	Description
1	Jamb bracket
2	Flat washer
3	Revit pin A
4	Arm
5	Revit pin B
6	Sleeve
7	End cap A
8	Spring
9	Shock block
10	Channel
11	Cam slider
12	End cap B

Typical door types for installation

